

Features

- ❖ User friendly touch screen panel
- ❖ Effective and user friendly cleaning solution
- ❖ Single side cleaning
- ❖ Static elimination and dust removal (vacuum)
- ❖ Minimum maintenance of cleaning system
- ❖ Smooth and parallel width adjustment (leadscrew)
- ❖ Small machine footprint
- ❖ SMEMA compatible

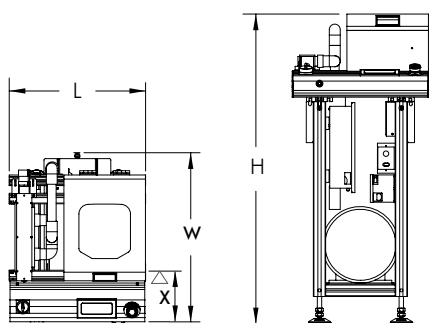
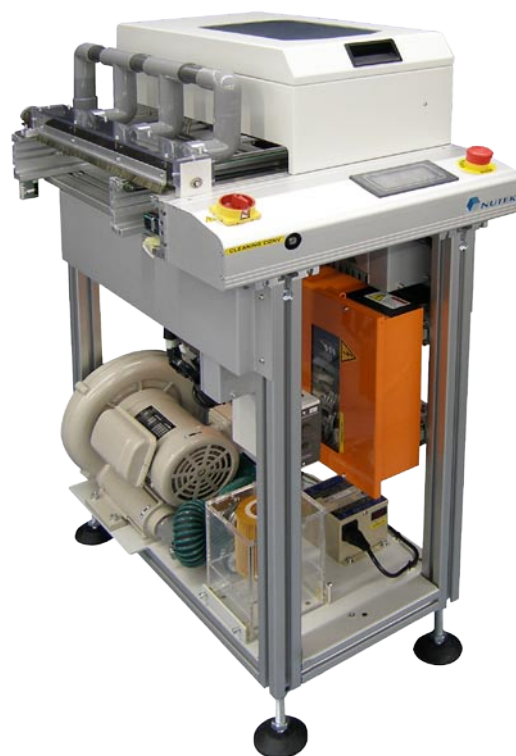

Plan View

Front View

Legend
 △ : Fixed Point

SPECIFICATIONS	
Description	This unit is used for removing dust, particles, glass fiber & etc on bare PCBs surface
Operating Suction	0.36Kw max.
Discharge	0.37Kw max.
Flow rate	1.4 m ³ /min.
Power Source	100, 230VAC 1Ph
Power Consumption	500VA max.
PCB Thickness	0.4 mm min.

Size	Model No.	Machine Dimension (mm) L x W x H	Fixed Point to Front Dimension (X)	Weight (Approximately)
M	NTM0401-C-M	500 x 620 x 1135	186 mm	120 kg
L	NTM0401-C-L	500 x 777 x 1135	186 mm	130 kg