

Features

- ❖ 10 Watt CO₂ (Class 4)
- ❖ Class 1 laser protected housing
- ❖ Air cooling system
- ❖ Fume extraction device
- ❖ User friendly software
- ❖ Short cycle time
- ❖ Selectable by-pass operation
- ❖ Automatic width adjustment conveyor
- ❖ PCB side clamping
- ❖ Short product change-over time
- ❖ Industrial PC & 21" LCD monitor
- ❖ Integrated inverting unit for double-sided marking (Optional)
- ❖ Barcode scanner or camera for readability check (Optional)
- ❖ SMEMA compatible

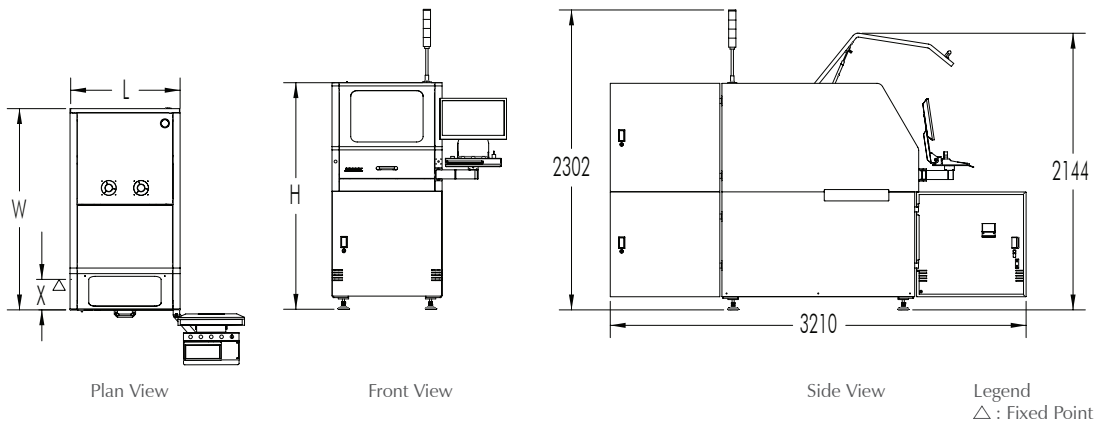

SPECIFICATIONS	
Description	This unit is used to mark text, barcode, 2D code & graphic onto PCBs.
Marking Area	350 x 350 mm total coverage
Cell Size	≥ 0.195 mm
Laser Wave Length	10.63 μm
Conveyor speed	24 m/min.
PCB transfer time	6 seconds
PCB Width	65 - 460 mm
PCB Length	80 - 508 mm
Power Source	100/230VAC 1Ph
Power Consumption	1600VA max.
Air Pressure	5 bar
Air Consumption	20 ltr/min. max.

Size	Model No.	Machine Dimension (mm) L x W x H	Fixed Point to Front Dimension (X)	Weight (Approximately)
XL	NTM5610-X	850 x 1558 x 1752	236 mm	640 kg